

	13	12	11	10	9	8	7	6	5	4	3	2	1					
J	UNPLATED MATERIAL NUMBER	UNPLATED ENG. NUMBER	UNPLATED MAT. NO. ON TAPE	UNPLATED ENG. NO. ON TAPE	PLATED MATERIAL NUMBER	PLATED ENGINEERING NUMBER	PLATED MAT. NO. ON TAPE	PLATED ENG. NO. ON TAPE	SEE DETAIL	STUD SIZE	AWG WIRE RANGE	"S"	"L"	"W"	"C"	"B"	"T"	J
	1922 10451	BCL-410	---	---	1922 10452	BCL-410-PL	---	---	---	10/(4.83)	4	.214/(5.45)	1.500/(38.10)	.531/(13.49)	.429/(10.90)	.286/(7.26)	.080/(2.03)	
	1922 10404	BCL-414	---	---	1922 10230	BCL-414-PL	---	---	---	1/4/(6.4)	4	.278/(7.06)	1.500/(38.10)	.531/(13.49)	.429/(10.90)	.286/(7.26)	.080/(2.03)	
	1922 10405	BCL-4516	---	---	1922 10231	BCL-4516-PL	1908 20025	BCL-4516-PLT	D	5/16/(7.9)	4	.340/(8.64)	1.500/(38.10)	.531/(13.49)	.429/(10.90)	.286/(7.26)	.080/(2.03)	
	1922 10461	BCL-4516-WP	---	---	1922 10460	BCL-4516-WP-PL	---	---	---	5/16/(7.9)	4	.340/(8.64)	1.531/(38.89)	.625/(15.88)	.397/(10.08)	.286/(7.26)	.080/(2.03)	
	1922 10383	BCL-438	---	---	1922 10232	BCL-438-PL	1908 20026	BCL-438-PLT	E	3/8/(9.5)	4	.400/(10.16)	1.500/(38.10)	.531/(13.49)	.429/(10.90)	.286/(7.26)	.080/(2.03)	
	1922 10458	BCL-438-WP	---	---	1922 10456	BCL-438-WP-PL	1908 20027	BCL-438-WP-PLT	E	3/8/(9.5)	4	.400/(10.16)	1.531/(38.89)	.625/(15.88)	.397/(10.08)	.286/(7.26)	.080/(2.03)	
	1922 10459	BCL-438-XWP	---	---	1922 10457	BCL-438-XWP-PL	---	---	---	3/8/(9.5)	4	.400/(10.16)	1.688/(42.88)	.766/(19.46)	.444/(11.28)	.286/(7.26)	.100/(2.54)	
I	1922 10453	BCL-412	---	---	1922 10454	BCL-412-PL	---	---	---	1/2/(12.7)	4	.520/(13.21)	1.688/(42.88)	.766/(19.46)	.444/(11.28)	.286/(7.26)	.100/(2.54)	I
	1922 10419	BCL-214	---	---	1922 10418	BCL-214-PL	1908 20001	BCL-214-PLT	C	1/4/(6.4)	2	.278/(7.06)	1.625/(41.28)	.625/(15.88)	.437/(11.10)	.336/(8.53)	.095/(2.41)	
	1922 10400	BCL-2516	---	---	1922 10233	BCL-2516-PL	1908 20002	BCL-2516-PLT	C	5/16/(7.9)	2	.340/(8.63)	1.625/(41.28)	.625/(15.88)	.437/(11.10)	.336/(8.53)	.095/(2.41)	
	1922 10380	BCL-238	---	---	1922 10235	BCL-238-PL	---	---	---	3/8/(9.5)	2	.400/(10.16)	1.625/(41.28)	.625/(15.88)	.437/(11.10)	.336/(8.53)	.095/(2.41)	
	1922 10564	BCL-238-WP	---	---	1922 10565	BCL-238-WP-PL	---	---	---	3/8/(9.5)	2	.278/(7.06)	1.750/(44.45)	.750/(19.05)	.474/(12.04)	.336/(8.53)	.095/(2.41)	
	1922 10399	BCL-212-WP	---	---	1922 10236	BCL-212-WP-PL	---	---	---	1/2/(12.7)	2	.520/(13.21)	1.750/(44.45)	.750/(19.05)	.474/(12.04)	.336/(8.53)	.095/(2.41)	
H	1922 10594	BCL-110	---	---	1922 10595	BCL-110-PL	---	---	---	#10/(4.83)	1	.214/(5.45)	1.718/(43.64)	.656/(16.66)	.446/(11.33)	.360/(9.14)	.100/(2.54)	H
	1922 10421	BCL-114	---	---	1922 10420	BCL-114-PL	---	---	---	1/4/(6.4)	1	.278/(7.06)	1.718/(43.64)	.656/(16.66)	.446/(11.33)	.360/(9.14)	.100/(2.54)	
	1922 10396	BCL-1516	---	---	1922 10237	BCL-1516-PL	---	---	---	5/16/(7.9)	1	.340/(8.63)	1.718/(43.64)	.656/(16.66)	.446/(11.33)	.360/(9.14)	.100/(2.54)	
	1922 10378	BCL-138	---	---	1922 10238	BCL-138-PL	---	---	---	3/8/(9.5)	1	.400/(10.16)	1.718/(43.64)	.656/(16.66)	.446/(11.33)	.360/(9.14)	.100/(2.54)	
	1922 10580	BCL-138-WP	---	---	1922 10581	BCL-138-WP-PL	---	---	---	3/8/(9.5)	1	.400/(10.16)	1.844/(46.84)	.750/(19.05)	.474/(12.04)	.360/(9.14)	.100/(2.54)	
	1922 10395	BCL-112	---	---	1922 10239	BCL-112-PL	---	---	---	1/2/(12.7)	1	.520/(13.21)	1.844/(46.84)	.750/(19.05)	.474/(12.04)	.360/(9.14)	.100/(2.54)	

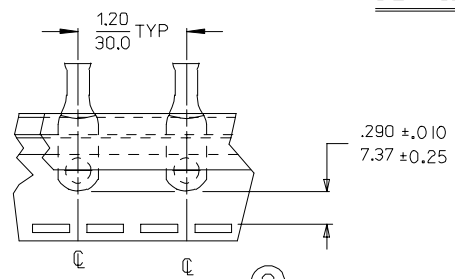
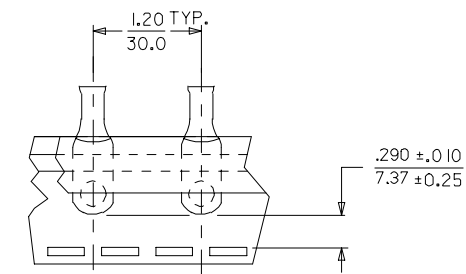
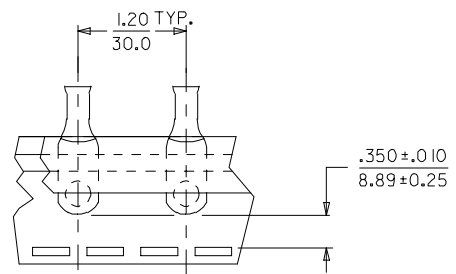
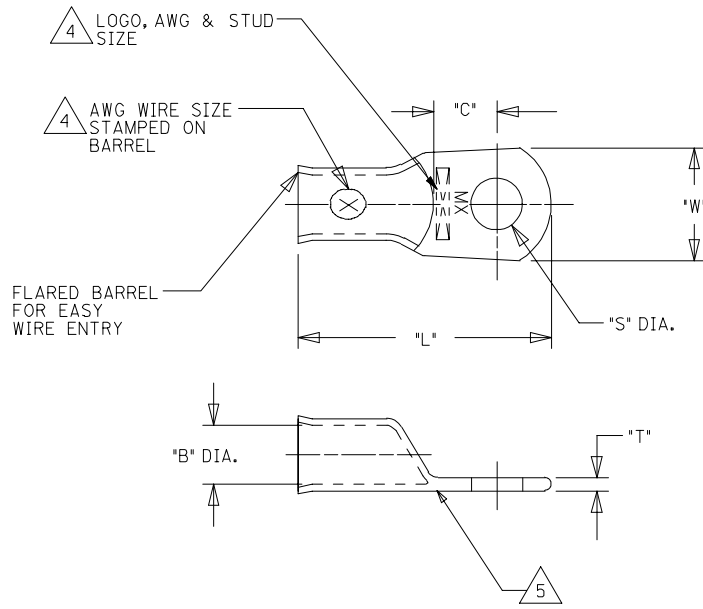

- NOTES:
- FOR INSPECTION SIGHT HOLE, PLEASE CONSULT FACTORY.
  - OTHER STUD SIZES MAY BE AVAILABLE, PLEASE CONSULT FACTORY.
  - MATERIAL: COPPER  
PLATING: TIN
  - MARKINGS CAN BE AT EITHER LOCATION SHOWN.
  - IF TONGUE IS TO BE BENT AT ANY ANGLE, IT MUST BE BENT AROUND A RADIUS ONE HALF THE TONGUE THICKNESS.

<b>ADDED DETAIL E</b> EC NO: ETC2006-0005 DR: WILLSHADECK 2005/11/23 CHKD: ROSS 2005/11/23 APPR: JPAWLICK 2005/11/23	QUALITY SYMBOLS 	GENERAL TOLERANCES (UNLESS SPECIFIED)		DIMENSION STYLE IN/MM		SCALE ---	DESIGN UNITS INCH	THIRD ANGLE PROJECTION		
		4 PLACES ± --- ± ---	3 PLACES ± --- ± ---	2 PLACES ± --- ± ---	1 PLACE ± --- ± ---	DRAWN BY BE	DATE 06/26/02	TITLE <b>EYELET STYLE COPPER TERMINALS 4, 2, &amp; 1 AWG LUGS</b>		
		ANGULAR ± --- °				CHECKED BY HB	DATE 06/26/02	<b>MOLEX INCORPORATED</b>		
		DRAFT WHERE APPLICABLE MUST REMAIN WITHIN DIMENSIONS				APPROVED BY RD	DATE 06/26/02	MATERIAL NO. <b>SEE CHART</b>	DOCUMENT NO. <b>SD-19221-010</b>	SHEET NO. <b>1 OF 1</b>

THIS DRAWING CONTAINS INFORMATION THAT IS PROPRIETARY TO MOLEX INCORPORATED AND SHOULD NOT BE USED WITHOUT WRITTEN PERMISSION